

# *CAPIOX<sup>®</sup> FX Family of Oxygenators with Integrated Arterial Filter*

*Breakthrough technology for added patient safety*

**With  
integrated  
filter!**

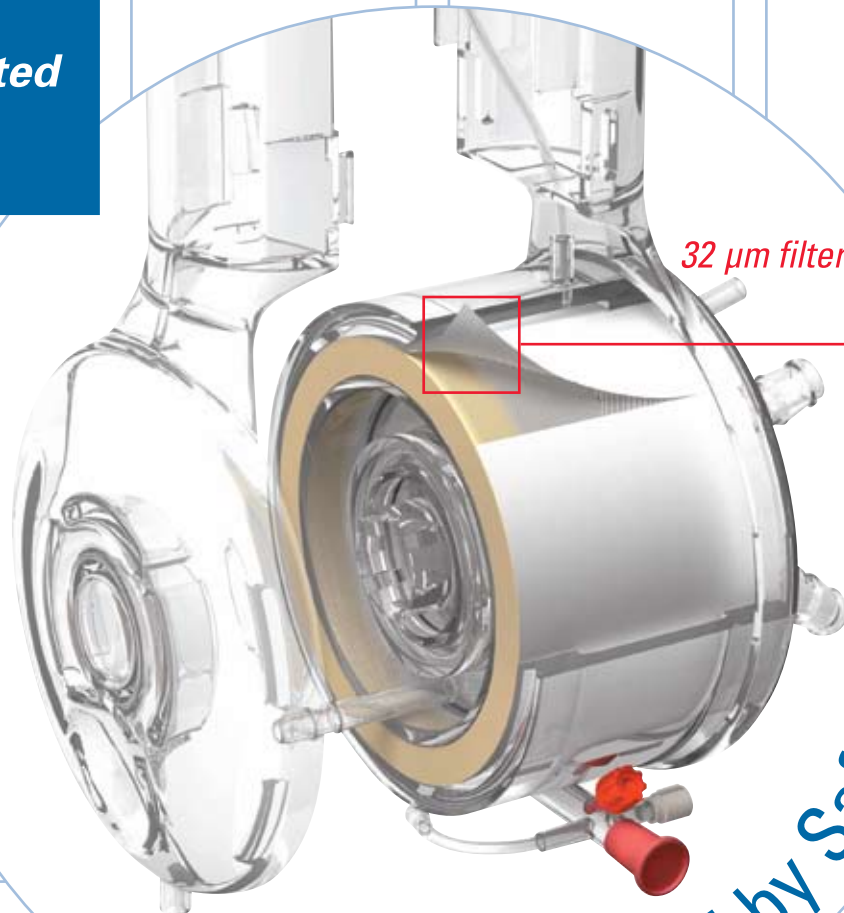

**Surrounded by Safety**

# CAPIOX<sup>®</sup> FX Family of Oxygenators

## Integrated arterial filter with self-venting technology

A 32  $\mu\text{m}$  screen filter surrounds the fiber layer of the oxygenator. Particulate micro-emboli that may be present in the blood are trapped in the filter mesh while gaseous emboli remain inside the oxygenator and in contact with the hollow fibers. Driven by the pressure difference, gaseous emboli enter the inner lumen of the microporous hollow fiber and are eliminated via the gas outlet.

CAPIOX<sup>®</sup> FX Family of Oxygenators

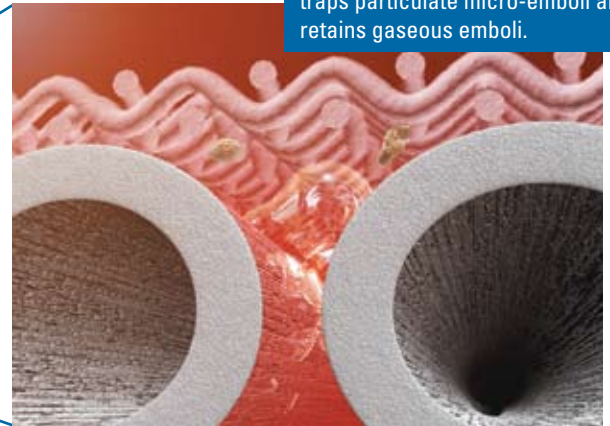
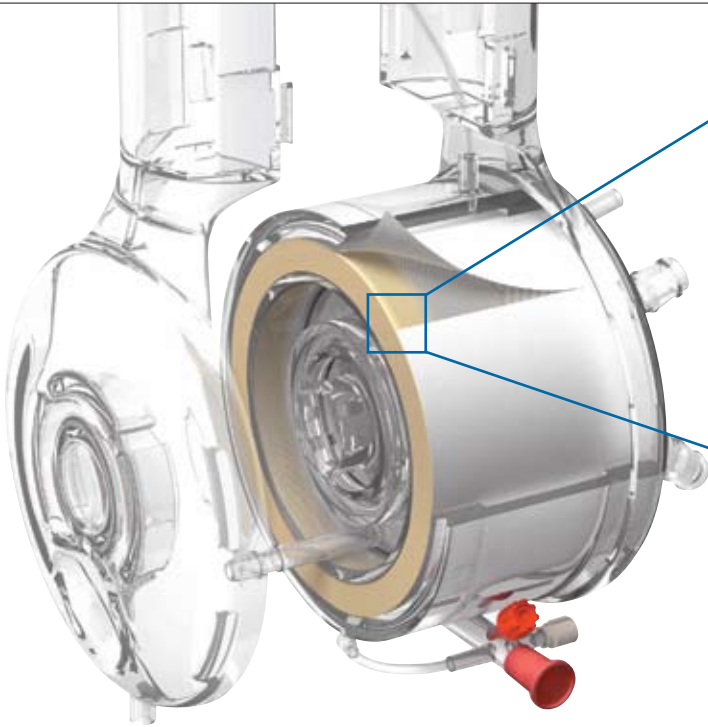

Screen filter surrounds the fiber layer, traps particulate micro-emboli and retains gaseous emboli.

Driven by the pressure difference between the blood side and gas side of the oxygenator, gaseous emboli enter the inner lumen of the microporous hollow fiber and are eliminated via the gas outlet.

Filter Pore Size 32  $\mu\text{m}$

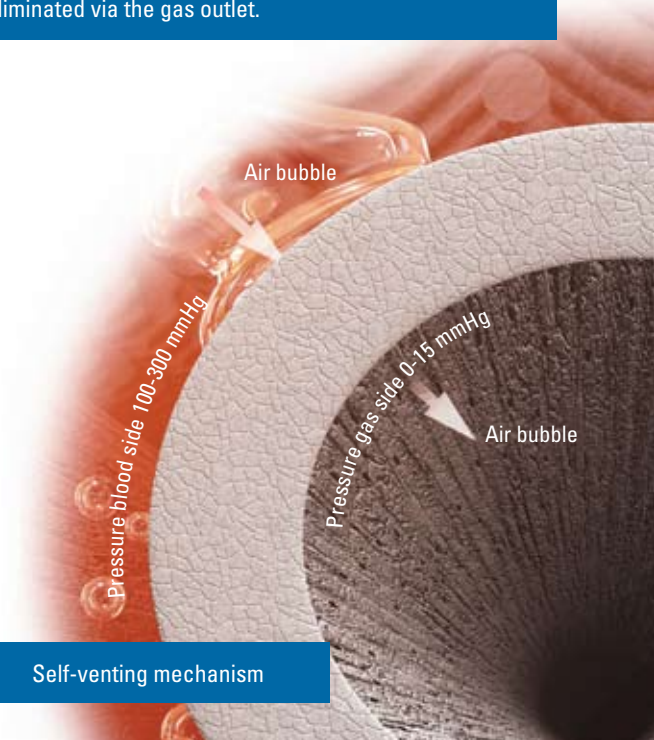

Self-venting mechanism

**Xcoating<sup>™</sup>**, Terumo's own biocompatible amphiphilic polymer surface coating, is a standard feature of all CAPIOX<sup>®</sup> FX oxygenators.

## *Integrated arterial filter*

- Filter inside oxygenator housing
- 32 µm pore size
- Self-venting technology

## *CAPIOX® FX05 Oxygenator* *For neonates and infants*

## *Oxygenator*

### Proven performance

- Fully integrated arterial filter with self-venting technology
- Low priming volume, high gas exchange and low pressure drop are optimally balanced for superb performance
- Hollow fibers manufactured exclusively by Terumo using a patented technology means total quality management from raw materials to finished product
- Woven fiber bundle ensures consistent and high-performance gas exchange
- Choice of blood outlet port configurations for easy access and increased circuit flexibility
- No DEHP used in PVC tubing



## *Hardshell Reservoir*

### Full featured

- Elongated shape provides stable blood flow path and enhanced visibility at all levels from all angles
- Rotating venous inlet improves set-up flexibility
- Connecting mount increases flexibility in circuit set-up and oxygenator rotation
- Funnel-shaped cardiotomy filter improves breakthrough and residual volumes
- No DEHP used in PVC tubing

- *Maximum blood flow: 1.5 L/min*
- *Oxygenator priming volume: 43 mL*
- *Arterial filter surface area: 130 cm<sup>2</sup>*
- *Reservoir storage capacity: 1000 mL*

#### West outlet port

Oxy inlet on right when outlet is facing away from user



#### East outlet port

Oxy inlet on left when outlet is facing away from user

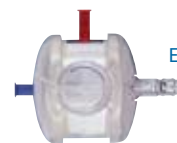

Choose the blood outlet port configuration that best suits your circuit

## CAPIOX® FX15 Oxygenator

For children, small adults and minimized circuits



Available in two reservoir sizes



- Maximum blood flow: 4.0 L/min
- Oxygenator priming volume: 144 mL
- Arterial filter surface area: 360 cm<sup>2</sup>
- Reservoir storage capacity: 3000 mL



- Maximum blood flow: 5.0 L/min
- Oxygenator priming volume: 144 mL
- Arterial filter surface area: 360 cm<sup>2</sup>
- Reservoir storage capacity: 4000 mL

## CAPIOX® FX25 Oxygenator

For all adults



- Maximum blood flow: 7.0 L/min
- Oxygenator priming volume: 260 mL
- Arterial filter surface area: 600 cm<sup>2</sup>
- Reservoir storage capacity: 4000 mL



### TOTM – an alternative plasticizer

Terumo is ever striving to develop new medical technologies with minimal negative impact to patients and the environment.

In line with this goal, Terumo provides an alternative plasticizer for the manufacturing of its products. TOTM (trioctyl trimellitate) offers outstanding physical properties (such as flexibility) to the material and low plasticizer elution.

# CAPIOX® FX05 Oxygenator Performance Data

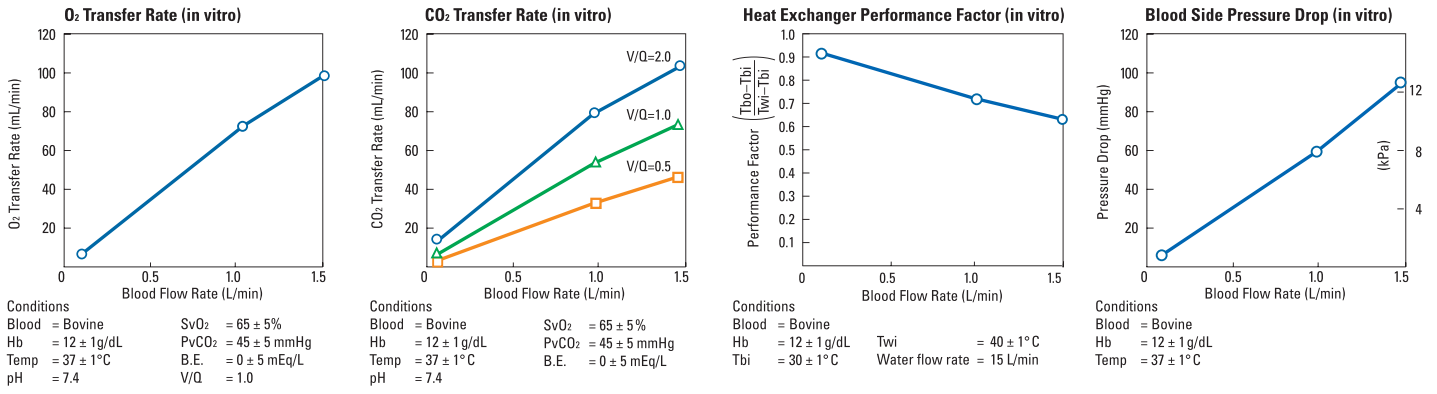

# CAPIOX® FX15 Oxygenator Performance Data

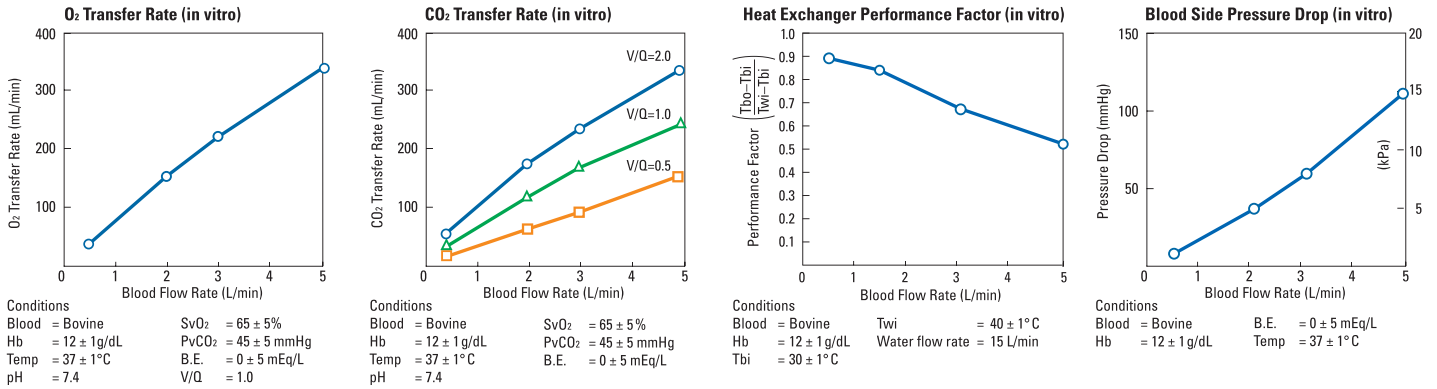

# CAPIOX® FX25 Oxygenator Performance Data

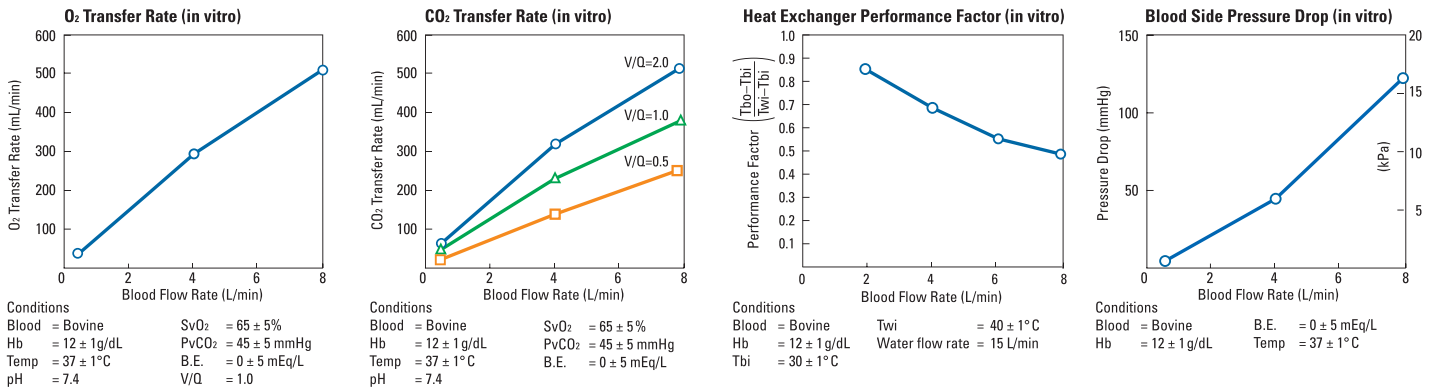

## Holder Systems

### CAPIOX FX05 Oxygenator



Order # XX\*CXH05R



Order # XX\*CXH05

### CAPIOX FX15 and CAPIOX FX25 Oxygenators



Order # 801804  
XX\*CXH18R (Europe only)



Order # 801139  
XX\*XH032 (Europe only)



Order # 812613 for FX25 (US only)  
812614 for FX15 (US only)  
XX\*CXH15 (Europe only)

# CAPIOX® FX Family of Oxygenators

## Specifications

### Oxygenator

Material	Housing	Polycarbonate
	Fibers	Microporous polypropylene
	Heat exchanger	Stainless steel

### Hardshell Reservoir

Material	Housing	Polycarbonate
	Venous filter	Polyester screen type, Pore size 47 µm
	Cardiotomy filter	Polyester depth type
	Defoamer	Polyurethane foam

Oxygenator	FX05	FX15	FX25
Fiber bundle surface area	Approx. 0.5 m <sup>2</sup>	Approx. 1.5 m <sup>2</sup>	Approx. 2.5 m <sup>2</sup>
Heat exchanger surface area	Approx. 0.035 m <sup>2</sup>	Approx. 0.14 m <sup>2</sup>	Approx. 0.2 m <sup>2</sup>
Blood flow range	0.1 – 1.5 L/min	0.5 – 5.0 L/min, 0.5 – 4.0 L/min (with R30)	0.5 – 7.0 L/min
Reference blood flow (AAMI std.)	2.5 L/min	7.0 L/min	n.a.
Priming volume (static)	43 mL	144 mL	260 mL
Blood inlet port (from pump)	1/4" (6.4 mm)	3/8" (9.5 mm)	
Blood outlet port	1/4" (6.4 mm)		3/8" (9.5 mm)
Cardioplegia port	–	1/4" (6.4 mm)	
Luer port (for recirc. or blood cardioplegia)	One luer lock on blood outlet port	n.a.	
Gas inlet port	1/4" (6.4 mm)		
Gas outlet port	5/16" (7.9 mm)	1/4" (6.4 mm)	
Water ports	1/2" (12.7 mm) Hansen quick-connect fittings		
Maximum pressure Blood inlet	1000 mmHg (133 kPa)		
Maximum pressure Water inlet	2 kgf/cm <sup>2</sup> (196 kPa) (28.5 psi)		
<b>Arterial filter</b>			
Filter material	Polyester screen type		
Pore size	32 µm		
Surface area	130 cm <sup>2</sup>	360 cm <sup>2</sup>	600 cm <sup>2</sup>

Hardshell reservoir	FX05	FX15 R30 (for FX15)	R40 (for FX15)	FX25
Blood flow range				
Venous flow	0.1 – 1.5 L/min	0.5 – 4.0 L/min	0.5 – 5.0 L/min	0.5 – 7.0 L/min
Cardiotomy inlet	Max. 1.5 L/min	Max. 4.0 L/min	Max. 5.0 L/min	Max. 5.0 L/min
Combined flow	Max. 1.5 L/min	Max. 4.0 L/min	Max. 5.0 L/min	Max. 7.0 L/min
Blood storage capacity	1000 mL	3000 mL	4000 mL	4000 mL
Min. operating volume	15 mL	70 mL	200 mL	200 mL
Venous blood inlet port	1/4" (6.4 mm) rotatable	3/8" (9.5 mm) rotatable	1/2" (12.7 mm) rotatable	1/2" (12.7 mm) rotatable
Blood outlet port (to pump)	1/4" (6.4 mm)	3/8" (9.5 mm)		
Suction ports	Five 3/16" – 1/4" (4.8 mm – 6.4 mm) rotatable	Six 1/4" (6.4 mm)		
Vertical port (to CR filter)	n.a.	3/8" (9.5 mm)		
Quick prime port	1/4" (6.4 mm)			
Vent port	1/4" (6.4 mm)			
Auxiliary port	1/4" – 3/8" (6.4 mm – 9.5 mm)			
Luer ports	Three filtered luer locks to cardiotomy filter, one non-filtered luer lock, two luer locks on venous inlet			
Maximum sustainable negative pressure in reservoir	-150 mmHg (-20.0 kPa)			

## Ordering Information

DESCRIPTION	CATALOG NO.	UNITS/CASE	DESCRIPTION	CATALOG NO.	UNITS/CASE
<b>CAPIOX FX05 Oxygenator</b>					
Oxygenator with integrated arterial filter <sup>1</sup>	CX*FX05W	4	Holder for FX05 oxygenator	XX*CXH05	1
Oxygenator with integrated arterial filter <sup>1</sup>	CX*FX05E	4	Holder for FX05 oxygenator with hardshell reservoir	XX*CXH05R	1
Oxygenator with integrated arterial filter/hardshell reservoir <sup>2</sup>	CX*FX05RW	4	Adapter for SX holder for FX05	XX*CXH05AD	1
Oxygenator with integrated arterial filter/hardshell reservoir <sup>2</sup>	CX*FX05RE	4	Holder for FX15/25 oxygenator with hardshell reservoir (short arm)	801139	1
<b>CAPIOX FX15 Oxygenator</b>					
Oxygenator with integrated arterial filter <sup>3</sup>	CX*FX15W	4	Holder for FX15/25 oxygenator with hardshell reservoir (long arm)	801804	1
Oxygenator with integrated arterial filter <sup>3</sup>	CX*FX15E	4	Holder for FX25 oxygenator (US only)	812613	1
Oxygenator with integrated arterial filter/hardshell reservoir <sup>4</sup>	CX*FX15RW30	2	Holder for FX15 oxygenator (US only)	812614	1
Oxygenator with integrated arterial filter/hardshell reservoir <sup>4</sup>	CX*FX15RE30	2	Holder for FX15/25 oxygenator (Europe only)	XX*CXH15	1
Oxygenator with integrated arterial filter/hardshell reservoir	CX*FX15RW40	2	Holder for FX15/25 oxygenator when separated from reservoir	XX*CXH25F	1
Oxygenator with integrated arterial filter/hardshell reservoir	CX*FX15RE40	2	Holder for FX15/25 oxygenator with hardshell reservoir (Europe only)	XX*CXH18R	1
<b>CAPIOX FX25 Oxygenator</b>					
Oxygenator with integrated arterial filter	CX*FX25W	4	Holder for FX15/25 oxygenator with hardshell reservoir, short arm (Europe only)	XX*XH032	1
Oxygenator with integrated arterial filter	CX*FX25E	4			
Oxygenator with integrated arterial filter/hardshell reservoir	CX*FX25RW	2			
Oxygenator with integrated arterial filter/hardshell reservoir	CX*FX25RE	2			

1 Contains 2 adapters 3/16" – 1/4" and a recirculation line  
 2 Contains 4 adapters 3/16" – 1/4", 1 adapter 1/4" – 3/8" and a recirculation line  
 3 Contains 2 adapters 1/4" – 3/8"  
 4 Contains 4 adapters 1/4" – 3/8"

CAPIOX® FX Family of Oxygenators



Terumo® and CAPIOX® are registered trademarks of Terumo Corporation. XCoating™ is a trademark of Terumo Corporation.  
 © 2009 Terumo Europe Cardiovascular Systems. Printed in the USA.

**TERUMO CARDIOVASCULAR SYSTEMS CORPORATION**  
 6200 Jackson Road  
 Ann Arbor, Michigan 48103-9300  
 USA  
 734 663 4145 phone  
 734 663 7981 fax  
 800 521 2818 toll free  
[www.terumo-cvs.com](http://www.terumo-cvs.com)

**TERUMO EUROPE N.V.**  
 Researchpark Haasrode 1520  
 Interleuvenlaan 40  
 B-3001 Leuven  
 Belgium  
 32 16 38 12 11 phone  
 32 16 40 02 49 fax  
[www.terumo-europe.com](http://www.terumo-europe.com)

**TERUMO EUROPE N.V. CARDIOVASCULAR DIVISION**  
 Hauptstrasse 87  
 D-65760 Eschborn  
 Germany  
 49 6196 8023 500 phone  
 49 6196 8023 555 fax  
[www.terumo-europe.com](http://www.terumo-europe.com)

**TERUMO LATIN AMERICA CORPORATION**  
 8750 NW 36th Street, Suite 600  
 Miami, Florida 33178  
 USA  
 305 477 4822 phone  
 305 477 4872 fax  
 800 283 7866 toll free

**TERUMO CORPORATION**  
 44-1, 2-chome  
 Hatagaya, Shibuya-ku  
 Tokyo 151-0072  
 Japan  
 81 3 3374 8111 phone  
 81 3 3374 8196 fax  
[www.terumo.com](http://www.terumo.com)